

Installation

Swisspearl Multi Force



Table of Contents

Product Description	3
Wall Types and Dimensions – Steel Frame	6
Wall Types and Dimensions – Wooden Frame	8
Exterior Wall and Shaft Wall	10
Ceilings, Balconies and Floors	11
Adjacent walls	12
Introduction to Sound Insulation	13
Sub-Construction	14
Surface treatment	15
Installation	16
Processing, Storing and Handling	18

Product Description

General

Swisspearl Multi Force is a fiber-cement board and is therefore strong and resistant to damp and mould. It also offers hard surface and high performance for fire protection and sound insulation.

Applications

Thanks to the unique product properties of Swisspearl Multi Force, it can be used for various different applications. Walls, both shaft- and partition walls where fire protection, sound insulation and durability are needed, are natural places for Swisspearl Multi Force. It can also be used in suspended ceilings, ceilings and balconies. Outdoor environment is not a problem as long as the product does not freeze when soaking wet. This means that you can install Swisspearl Multi Force to places like soffit, where a double layer of Swisspearl Multi Force 12 mm provides you with EI 30 resistance to fire.

Appearance

Easily recognizable with its cement grey and glittering surface. The long edges of the standard boards are beveled (2-2mm 45°) and have predrilled holes (not penetrating the board).

Fire Protection

Today safety in buildings is as important as ever. To answer the increasing requirements in fire protection, Swisspearl continuously develops and tests solutions for improved fire protection performance. Swisspearl Multi Force answers the increasing fire protection needs in especially wall and ceiling applications.

Reaction to fire according to EN 13501-1:2007+A1:2009 for Swisspearl Multi Force is the best possible non-combustible class A1. Large variety of structures for partition-, shaft- and exterior walls as well as ceilings and balconies have been tested according to EN 1364 and EN 1365 parts 1 and 2. The list of structures and classifications can be found from pages 5-10. In addition, one layer of Swisspearl Multi Force 9 mm gives K210 and K110 covering performance according to EN 13501-2:2007+A1:2009.

Sound Insulation

The combination of weight and stiffness means that Swisspearl Multi Force has high sounds insulation performance. General details related to sound insulation:

- E-modulus: 7 GPa
- Density: 1150 kg/m³
- Airborne sound insulation:
- 9 mm: 28 dB
- 12 mm: 31 dB

More details about the sound insulation can be found from pages 5 to 12.

Strength and Impact Resistance

Swisspearl Multi Force is a strong board for harsh environments. The number of boards and frame c-c spacing can be combined for various requirements. The diagram shows how to build the wall for various different requirements.

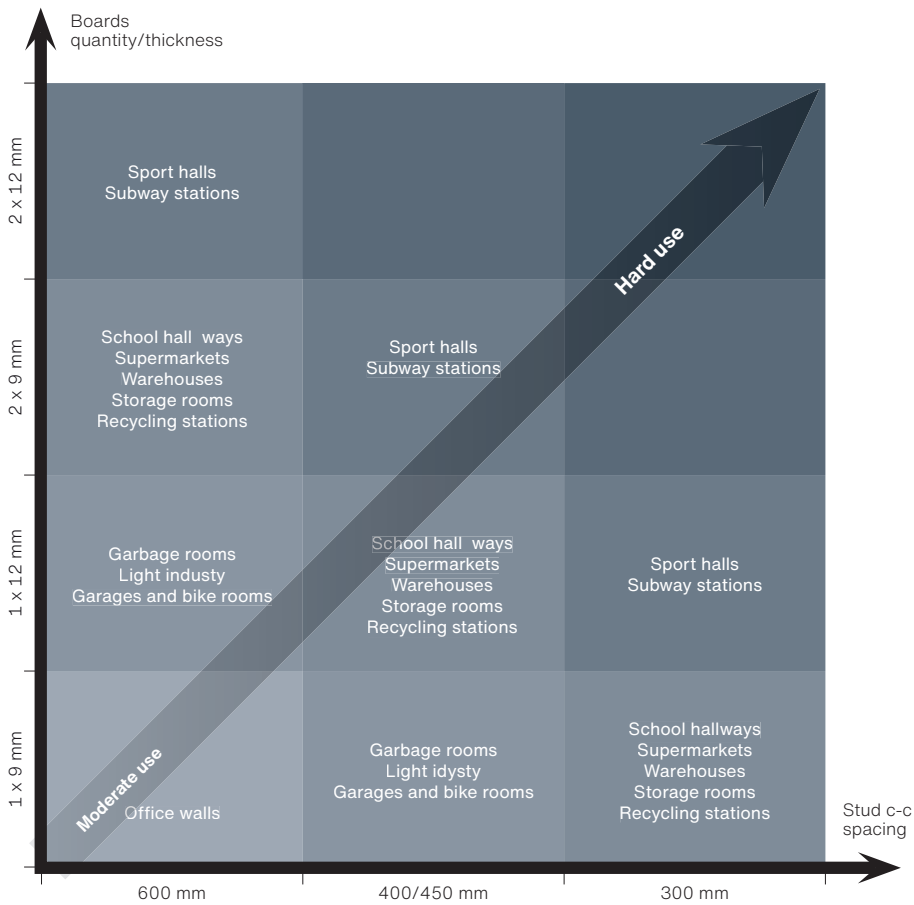

Water Resistant

Virtually unaffected by being wet. Can tolerate pressure washing, absorb and release damp in an infinite number of cycles without losing density or strength.

Resistant to Mould and Rot

The high pH value (11) prevents the growth of mould and other micro-organisms. The boards cannot rot, rust or degrade in any way in damp environments. Technical Research Institute of Sweden (SP) found it almost impossible to provoke mould growth on Swisspearl Multi Force and therefore uses the product as reference for comparison of other materials.

Resists Biological Attack

Unaffected by micro-organisms, alkaline or organic solvents. Can however be affected by acids, such as sulphuric and nitric acid. Pests such as mice and insects cannot touch Swisspearl Multi Force.

Heat Resistant

Tolerates constant heat up to + 150 °C.

Tolerates Cleaning

An untreated Swisspearl Multi Force tolerates cleaning with light high pressure washing and using mechanical aids. Another method for cleaning is to use a detergent solution followed by plentiful rinsing.

If heavy soiling and high exposure to chemicals, oil etc., we recommend surface treatment with a silane / siloxane sealer or a concrete impregnator / sealer.

Edges

Standard Swisspearl Multi Force has beveled edges (2-2mm 45°). The boards are installed with butt joints. The beveled profile makes it easy to obtain a decorative effect. For a specific order the long edges can also be left square, or for the 12 mm thick board, the edges can be chamfered approx. 50 mm width and 1-2 mm depth.

Standard

V-beveled edge 9 and 12 mm

Make to order

Chamfered edge 12 mm



Square edge 9 and 12mm

Health and Environment

Swisspearl Multi Force consists of cement, limestone, mica and cellulose fibers. None of the contents are hazardous to health, including any dust created by cutting the boards. In emission tests by VTT in Finland, Swisspearl Multi force reached the best possible M1 classification. Environmental product declaration (EPD) for Swisspearl Multi Force can be found from www.Swisspearl.com

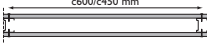
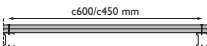
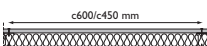

Wall Types and Dimensions – Steel Frame

Fire Protection	Sound Insulation R _w [dB]	Max. Wall Height mm		Thickness mm	Wall Structure	Structure Code	Dimensions
		c/c 450	c/c 600				
EI 30	30	3000	69	E 45/45 12-12 M0	S1a		
			94	E 70/70 12-12 M0	S1b		
			119	E 95/95 12-12 M0	S1c		
	35	3000	81	E 45/45 9+9-9+9 M0	S2a		
							35
	40	4000	69	E 45/45 12-12 M45	S4a		
				40	4000		94
	40	3000	88			E 70/70 9-9 M70	
				40	3000		81
	44	4000	112			E 70/70 9+12-12+9 M70	
44				4000	119		E 95/95 12-12 M95
	EI 60	35	3000			93	
40				4000	94		E 70/70 12-12 S70
		40	4000			113	
40				4000	118		E 70/70 12+12-12+12 M0
		40	4000			119	
44				4000	143		E 95/95 12+12-12+12 M0

Wall Types and Dimensions – Steel Frame

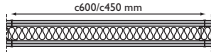
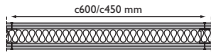
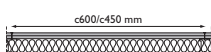
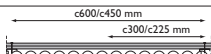
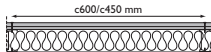
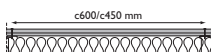
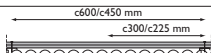
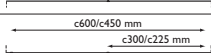
Fire Protection	Sound Insulation R _w [dB]	Max. Wall Height mm		Thickness mm	Wall Structure	Structure Code	Dimensions
		c/c 450	c/c 600				
EI 90	40	3000		81	E 70/70 9+9-9+9 S70	S17a	
	44	4000		106	E 45/45 9+9-9+9 M0	S18a	
	48	4000		131	E 95/95 9+9-9+9 S95	S19a	
	48	4000		131	D 70/95 9+9-9+9 S95	S20a	
EI 120	44	4000		112	E 70/70 9+12-12+9 S70	S21a	
	48	4000		137	E 95/95 9+12-12+9 S95	S22a	
	48	4000		131	D 70/95 9+9-9+9 S95	S23a	
	55	4000		186	DD 70/70 9+9-9+9 S140	S24a	

Explanations (walls):

E 45/45 12-12 M0: Single post; 45 mm post/45 mm rail; 12 mm Multi Force – 12 mm Multi Force; Mineral wool 0 mm; No. S1a
 E 45/45 9+9-9+9 S45: Single posts; 45 mm post/45 mm rail; 9+9 mm Multi Force - 9+9 mm Multi Force; rock wool 45 mm; No. S17a
 Multi Force D 70/95 9+9-9+9 M95: Split-level posts; c/c between posts 300/225 mm; 70 mm post/95 mm rail; 9+9 mm Multi Force – 9+9 mm Multi Force; Mineral wool 95 mm; No. S20a
 DD 70/70 9+9-9+9 S140: Double posts; c/c between posts 300/225 mm; 70 mm posts/70 mm rail; 9+9 mm Multi Force – 9+9 mm Multi Force; Rock wool 140 mm; No. S24a.

Explanations (other):

Steel profiles: Hot-galvanized, cold-rolled sheets according to DS/EN 10327:2004

Steel rails: 0.56x30/b/30 mm, Z 275; b = rail width (45, 70 or 95 mm)

Steel posts: 0.56x5/40/h/43/5 mm, Z 275; h = profile height (45, 70 or 95 mm)

M: Mineral wool – glass wool or rock wool

NOTE!

For EI 60 and up applies that rock wool must have a minimum density of 28kg/m³

S24a: 10 mm minimum distance between rails

Wall Types and Dimensions – Wooden Frame

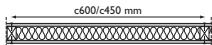
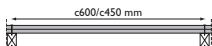
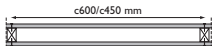
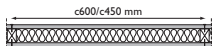
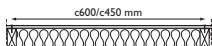
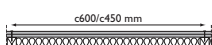
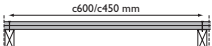
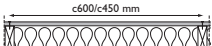
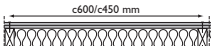
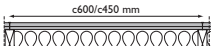
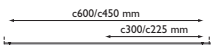
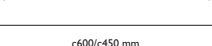
Fire Protection	Sound Insulation R _w [dB]	Max. Wall Height mm		Thickness mm	Wall Structure	Structure Code	Dimensions	
		c/c 450	c/c 600					
EI 30	30	3000		63	E 45/45x45 9-9 M45	W1a		
	30	3000		81	E 45/45 9+9-9+9 M0	W2a		
	30	3000		69	E 45/45 12-12 M0	W3a		
	30	4000		94	E 70/70 12-12 M0	W3b		
	35	4000		119	E 95/95 12-12 M0	W3c		
		35	3000		69	E 45/45 12-12 M45	W4a	
		35	4000		88	E 70/70 9-9 M70	W6a	
		35	3000		81	E 45/45 9+9-9+9 M45	W7a	
		35	4000		106 131	E 70/70 9+9-9+9 M0 E 95/95 9+9-9+9 M0	W8a W8b	
	REI 30/EI 30	35	4000		119	E 95/95 12-12 M95	W9a	
EI 30	40	4000		106 131	E 70/70 9+9-9+9 M70 E 95/95 9+9-9+9 M95	W10a W10b		
	44	4000		137	E 95/95 9+12-12+9 M95	W11a		
	48	4000		131	D 70/95 9+9-9+9 M95	W12a		
	55	4000		176	DD 70/70 9+9-9+9 M2x70	W13a		

Wall Types and Dimensions – Wooden Frame

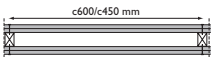
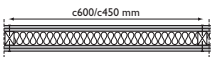
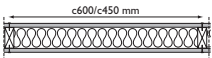
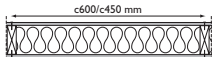
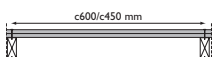
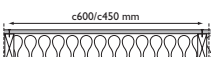
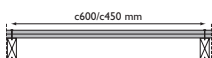
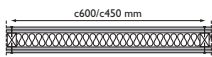
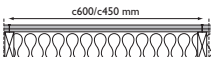
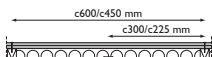
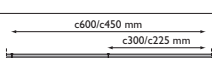
Fire Protection	Sound Insulation Rw [dB]	Max. Wall Height mm		Thickness mm	Wall Structure	Structure Code	Dimensions
		c/c 450	c/c 600				
EI 60	35	3000		93	E 45/45 12+12-12+12 M0	W14a	
	35	3000		81	E 45/45 9+9-9+9 S45	W15a	
	35	4000		94	E 70/70 12-12 S70	W16a	
	35	4000		113	E 95/95 9-9 S95	W17a	
REI 30/EI 60	35	4000		118	E 70/70 12+12-12+12 M0	W18a	
EI 60	35	4000		119	E 95/95 12-12 S95	W19a	
REI 30/EI 60	40	4000		143	E 95/95 12+12-12+12 M0	W20a	
REI 60/EI 90	40	4000		106	E 70/70 9+9-9+9 S70	W21a	
				131	E 95/95 9+9-9+9 S95	W21b	
EI 120	44	4000		137	E 95/95 9+12-12+9 S95	W22a	
	48	4000		131	D 70/95 9+9-9+9 S95	W23a	
	55	4000		186	DD 70/70 9+9-9+9 S140	W24a	

Explanations (walls):

E 45/45 9-9 M45: Single posts; 45 mm post/45 mm rail; 9 mm Multi Force – 9 mm Multi Force; Mineral wool 45 mm; No. W1a
 E 45/45 9+9-9+9 S45: Single posts; 45 mm post/45 mm rail; 9+9 mm Multi Force - 9+9 mm Multi Force; rock wool 45 mm; No. W15a
 D 70/95 9+9-9+9 S95: Split-level posts; c/c between posts 300/225 mm; 70 mm post/95 mm rail; 9+9 mm Multi Force – 9+9 mm Multi Force; Rock wool 95 mm; No. W23a
 DD 70/70 9+9-9+9 S140: Double posts; c/c between posts 300/225 mm; 70 mm posts/70 mm rail; 9+9 mm Multi Force – 9+9 mm Multi Force; Rock wool 140 mm; No. W24a

Explanations (other):

Wooden rails: 45xb mm; b = rail width (45,70 or 95 mm)
 Wooden posts: 45xh mm, h = post height (45,70 or 95 mm)
 M: Mineral wool – glass wool or rock wool

NOTE!

For EI 60 and up applies that rock wool must have a minimum density of 28kg/m³
 W24a: 10 mm minimum distance between rails

Exterior Wall

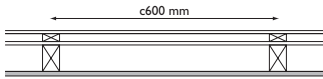
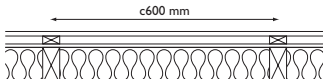
Construction	Fire Proof Rating	Sound Insulation R _w	Structure of the Construction	Dimensions
Exterior wall, Y1	EI 30	35	Swisspearl facade board EPDM strips 21x45 mm stud 4.5 mm Swisspearl Windstopper Extreme 45x70 frame/stud c/c 600 12 mm Swisspearl Multi Force	
Exterior wall, Y2	REI 30/ EI 60	40	Swisspearl façade board EPDM strips 21x45 mm stud 4.5 mm or 9 mm Swisspearl Windstopper Extreme 45x95 frame/stud c/c 600 mm 95 mm rock wool 30 kg/m ³ 12 mm Swisspearl Multi Force	

Shaft Wall

Fire Protection	Sound Insulation R _w	Max. Wall Height	Thickness	Wall Structure	No.
EI 15	28	3000	12	1x12 mm Swisspearl Multi Force, Steelpost R70 max 600 mm c/c	SV 1a 
EI 30 / E 90	30	3000	24	2x12 mm Swisspearl Multi Force, Steelpost R70 max 600 mm c/c	SV 1b 
EI 60	36	3000	44	1x12 mm Swisspearl Multi Force, 20 mm glass wool 15kg/m ³ , 1x12 mm Swisspearl Multi Force, Steelpost R70 max 600 mm c/c	

Explanations (walls):

Wood profiles: Must comply with the regulations drawn up by The Danish Society of Engineers, IDA Steel profiles: Hot-galvanized, cold-rolled sheets according to DS/EN 10327:2004

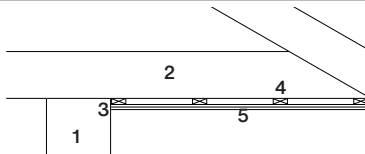

Roof eaves

Fire Protection	Thickness	Roof eaves structure	No.
EI 30	24	<ol style="list-style-type: none"> External wall EI30 - EI60 Roof truss max c1200 Fire seal 28x70mm batten, gauge max c400 2x12mm Multi Force 	ER 1a 

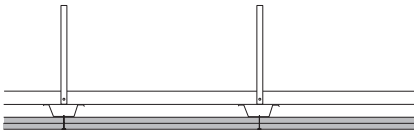
Suspended Ceilings

Fire Protection	Sound Insulation R _w	Wall Structure	No.	
EI 30 / E60	28	Steel hangers 1x25 c/c 500mm Secondary profile FR 66/55 c/c 1200mm Primary profile 20/25/70/25/20 c/c 400mm 2 x 12 mm Swisspearl Multi Force	SC1	 2x12 mm

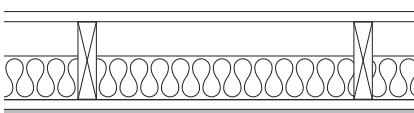
Balconies, Ceilings and Floors

Fire Protection	Sound Insulation R _w	Wall Structure	No.	
REI 30	32	Wood planks 22 mm, Wood beams 45 x 170 c/c 600mm, Rockwool 95mm, Wood planks 28x70 c/c 450mm 12mm Swisspearl Multi Force	F1	 12 mm
REI 60	40	Wood planks 20 mm, Wood beams 48 x 148 c/c 600 mm, Wood planks 20 mm c/c 400mm, 2 x 12 mm Swisspearl Multi Force	F2	 2x12 mm

Ceilings

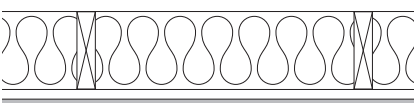
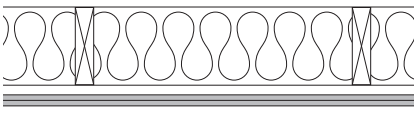
Fire Protection	Sound Insulation R _w	Wall Structure	No.	
REI 30	28	45 x 170 mm Wood beam c/c 600 mm, 170 mm Rockwool min 28 kg/m ³ , Vapor barrier, 28 x 70 Wood blanks 1 x 12 mm Swisspearl Multi Force	C1	 12 mm
REI 60	32	45x170 mm Wood beams c/c 600 mm, 170 mm Rockwool min 28 kg/m ³ , Vapor barrier Hat profile steel 25/80 max c/c 450 mm, 2x12 mm Swisspearl Multi Force	C2	 2x12 mm

Adjacent walls

R'_w 35-40 dB

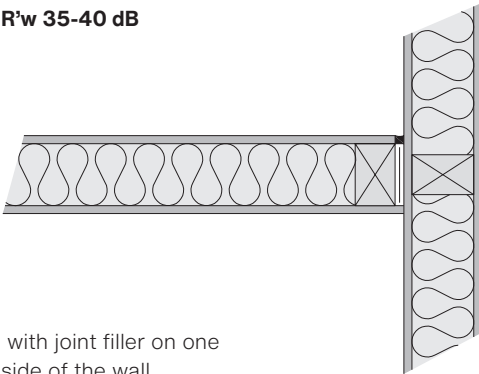

with joint filler on one side of the wall.

R'_w 44-48 dB

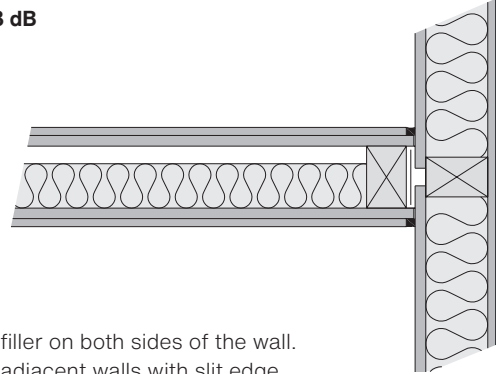

with joint filler on both sides of the wall.
Boards in adjacent walls with slit edge.

R'_w 40-44 dB

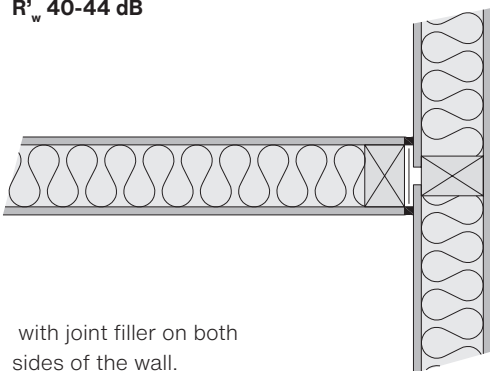

with joint filler on both sides of the wall.

R'_w >52 dB

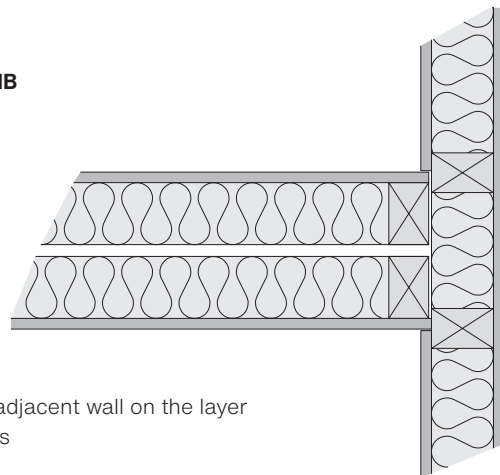

against adjacent wall on the layer of battens

R'_w 40-44 dB

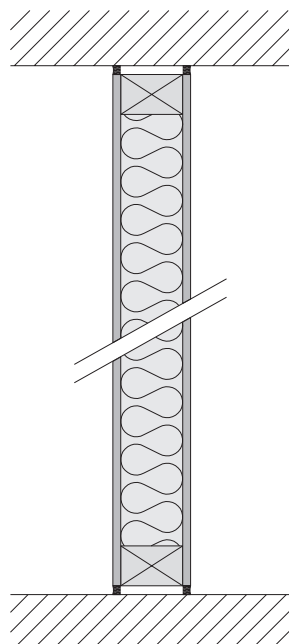

against floor, wall and ceiling with joint filler on both sides of the wall.

Introduction to Sound Insulation

Planning on the basis of predetermined requirements for airborne sound insulation

Light partitions are always expected to have lesser sound proofing properties when installed in buildings than those measured in laboratories. The primary causes are sound transmission around the partition and variations in the installations. e.g. the coupling of edges in double walls as well as minor leaks. The difference between laboratory values and field values often amounts to 4-7 dB.

Usually the flanking constructions and the joints should be dimensioned and performed in such a manner that the total sound transmission around the partition does not exceed the sound transmission through the wall. With the basis, the values for R_w as specified in the tables on page 4-8, can be applied. In case of doubt, an evaluation by an acoustic expert must be conducted, for instance on the grounds of calculations according to EN 12354-1:2000 with the SEBASTIAN software. Likewise, calculations of other single number values than R_w can be made by an acoustic expert on the basis of the reduction figure per 1/3 octave.

Calculation of sound insulation for a combined construction, e.g. a wall with a door, must be carried out in accordance with EN 12354-1:2000 in order to achieve the most realistic values. The following offers some important guidelines concerning ways to avoid undesired sound transmission.

However due to the high variation between the sound insulation of partitions, as indicated in the tables on page 4-8, the guidelines do not apply to all possible situations.

All lightweight, flanking walls and ceilings, including form-works, must be separated from the partition. The same applies to floating floors. In light roof constructions, the direction of the rafters must be parallel with the partition, unless a special kind of elastic ceiling suspension is used.

Sound proof insulation for transmission through heavy, flanking walls and floors corresponds to at least the laboratory value for the light weight partition used. The partition must be tight (applies to surfaces, joints and lead-ins). Leaks might arise for instance in connection with pipe lead-ins and in fixing the partition into heavy building elements. Pipe lead-ins, etc. are sealed with mineral wool stopping and elastic joint filler from both sides. Electric installation sockets, etc. are supplied from each side. The sockets can be placed on either side of the wall, provided that there are no leaks in the cladding.

Along edges against adjacent building elements, elastic joints are placed on both sides of the wall. However, with R_w requirements below 44 dB, a joint on one side is sufficient.

Sound Insulation Requirements

The sound insulation requirements in a building might be stipulated by the builder or the authorities. The airborne sound insulation values are important to determine in connection with the planning of the structural design, as it will be difficult and costly to improve the values, when the building element is completed.

Concerning pipe lead-ins, the fact that radiators might transmit airborne sounds from one room to another, if they are connected with short, unbroken heat pipes must be taken into account.

Sound transmission through ventilation channels or fresh air intakes without appropriate sound reduction may decrease the sound proof insulation considerably. The risk of such reduction is greatest between fittings connected to the same string and between fresh air intake with a spacing less than 2 m. To avoid sound transmission via roof spaces most efficiently, the partition must be lead all the way to the ridge. Alternatively,

Sub-Construction

Swisspearl Multi Force must be fixed to a dry and even subconstruction with a max support width of 600 mm (c/c distance). Max distance between fixing points must not exceed 400 mm.

All vertical board edges are to be supported by studs. Horizontal board edges must always be supported by a batten or a board material strong enough to fix the screws for fixation. Swisspearl MF boards are fixed with butt-joints.

If the wall construction is made of several layers of e.g. chipboards under the Multi Force boards these should have the same width 900 mm or 1200 mm. The underlying boards should be fixed in an upright position according to the supplier's recommendations, and the next layer should be staggered. Regardless of the number of layers the max support distance is 600 mm c/c.

In case of 2 layers of Multi Force boards there must be a min 150 mm overlap at horizontal joints. Timber studs are to be made of planed wood with full size edges in dimensions according to the actual load (min 45x45 mm).

Steel studs should be made of cold rolled steel according to EN10327:2004 with a min thickness of 0.56 mm, and hot dipped galvanized with a coating thickness min 20 µm (275 g/m²).

Acoustic Insulation

For achieving a good sound reduction a felt material is fixed onto the sub-construction at the connections to floors, walls and ceilings. For increasing the sound reduction the edges of the inner boards can be sealed with a mastic or silicone sealant.

All edges must be supported. Joints should be staggered min 300 mm, also by multiple layers. Joints may not be flush with door and window openings. By multiple layers this only counts for the outer board. Vertical joints should be established on the same stud on both sides of the wall.

Surface treatment

Before painting

Cleaning the boards from dust is very important in order to get good adhesion for the paint. Screw heads and scratches should be filled and the beveled joints left visible. The boards need to be dry for painting.

Painting

Swisspearl Multi Force can be painted with paints suitable for concrete surfaces, such as latex or acrylic based paints. Oil and alkyd based paints that don't have resist alkaline do not work with Swisspearl Multi Force. Follow the paint supplier's instructions.

Water resistant surface

For a dirt and water resistant surface, we recommend that Swisspearl Multi Force is treated with a silane / siloxane sealer or a concrete impregnator / sealer. The finishing look will be transparent, matt surface with the boards' natural color.

Outdoor use

Swisspearl Multi Force can be used outdoors in places where it is protected from rain. These applications include soffits, partitions between glazed balconies, balcony ceilings and shelters. In these applications a 12 mm thick Swisspearl Multi Force is to be used. The boards can be painted with alkali resistant paints meant for concrete surfaces for outdoor use. Proven solutions include socle paints such as Tikkurila Yki. Painting needs to be done according to paint supplier's instructions.

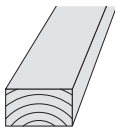
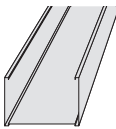
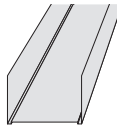
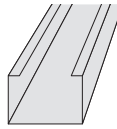

Installation

	Wooden Frame	Steel Frame	Steel Frame	Steel Frame
				
Dimensions	45 x 45 45 x 70 45 x 95	R 45/40 R 70/40 R 95/40 Material thickness 0,56 mm	SK 45/37 SK 70/37 SK 95/37 Material thickness 0,56 mm	FR 45 FR 70 FR 95 Material thickness 1,2 mm
Application	Vertical posts	Vertical rails	Rails near ceilings, floors, and floor joists	Stabilising rails for doorways

Supports / Wall Heights

Studs	Board layer(s)	Max Wall height
Wood 45x45	1 layer	3000 mm
Steel R45	1 layer	3000 mm
Wood 45x70	1 or 2 layers	4000 mm
Steel R70	1 or 2 layers	4000 mm

Support and fixing distances – Steel Frame

Perimeter frame: Steel rails are fixed per 400 mm with screws appropriate for the substrate.

Fastening

Swisspearl Multi Force is fastened with screws (see below table). No pre-drilling is needed. Normally the screw heads are fixed to the level of the board surface. If a blind fixation is desired the screw heads can be countersunk 1/2-1 mm.

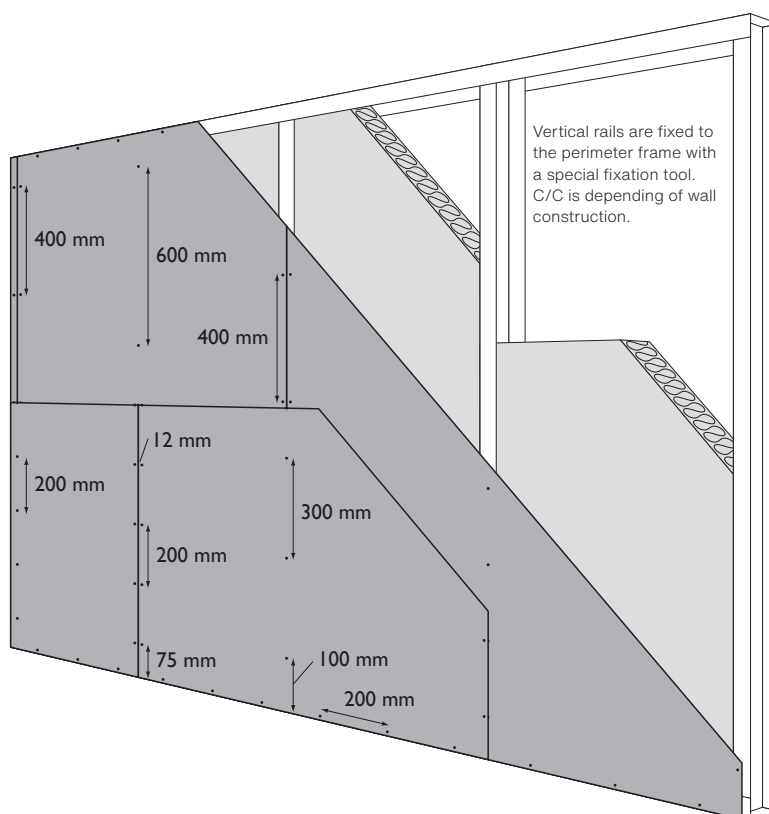

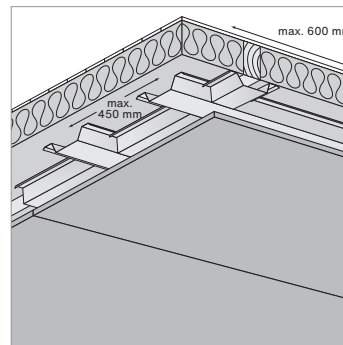
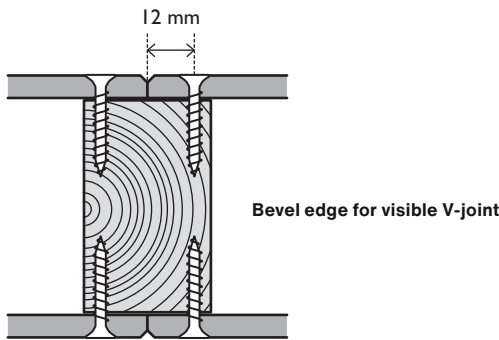

Floor division

Screw distances

Partition walls and ceilings	Distance
Supported edges	200 mm
Intermediate supports	300 mm
Vertical corner distance	75 mm
Min. edge distance	12 mm

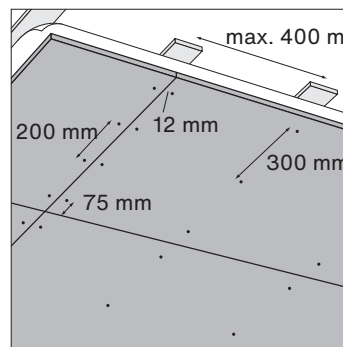

Ceiling

Fixing on steel max 1.2 mm	Fixing on steel	Fixing on wood	Fixing on wood
Board layers	Screw	Board layers	Screw
≤12 mm	SCR-S 4.2x30 mm Universal	≤12 mm	SCR-W 3.9x38 mm Universal or SCR-W 4.2x35 mm Yellow Plated
12-24 mm	SCR-W 3.9x38 mm Universal	12-24 mm	SCR-W 4.2x45 mm Yellow Plated

Fastenings

Swisspearl Multi Force boards are strong and durable. They can therefore support a wide range of interior items that would normally require reinforcement behind the board. When reinforcements are required, they can be provided as fixtures, reinforcement sheet metal or plywood.

1. Without reinforcement

Normal interior items that do not require reinforcement include cabinets, shelves and handrails. The table shows examples of fastenings and dimensioning loads for 9mm thick boards.

2. With reinforcement sheet metal or plywood

When loads are greater than above, fastenings need to be reinforced using sheet metal or plywood sheets between the studs. Examples: heavy shelves and wash basins.

Fastenings	Max load kg Shear load	Max load kg Pulling	Examples
	7,5	-	
	15	-	Mirrors, hooks, light shelves
	35	17,5	
	60	37,5	
	85	30	Cabinets, light shelves and hooks
	90	37,5	

Processing

Safety

As for all other building materials safety precautions must be taken into account and local laws and regulations must be observed.

Swisspearl Multi Force boards do not contain any dangerous or harmful substances, nor do they give off any fumes that could be a health hazard.

Today, no specific requirements exist as to the methods and tools used when installing the Swisspearl Multi Force boards.

Cutting and drilling are however subject to dust development, and proper precautions must be taken. Dust from fibre cement boards is characterized as mineral dust and a prolonged exposure to this may cause lung disease.

Cutting

Cutting to size may be done with normal slow running (2000 rpm) circular saw. Sharp edges are made with fast running diamond tipped tools. Dust exhaustion must be employed. For the best result the boards should be cut backside up.

Swisspearl sawblades

Diameter	Ø160	Ø190	Ø216	Ø250	Ø300
Width mm	2.4 mm	2.4 mm	2.6 mm	2.6 mm	2.8 mm
Hole size	20 mm	30 mm	30 mm	30 mm	30 mm
Rpm	4800	4000	3500	3000	2800

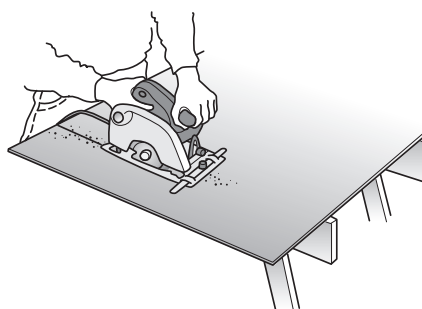
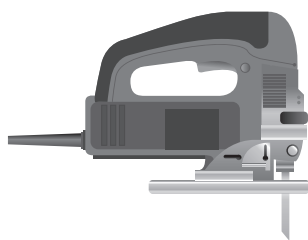

Cut-outs and bigger holes may be made with a jigsaw equipped with a hard metal, bi-metal or diamond tipped blade. A min 8 mm hole is to be drilled at the inner corner to avoid cracking of the board. Smaller holes can be made with a keyhole saw.

As an alternative it is possible to score the boards on the front side with a hand-scriber and break them over a sharp edge. Fins should be removed before fixing the board.

Cut-outs may be made with a jigsaw equipped with a hard metal, bi-metal or diamond tipped blade. A min 8 mm hole is to be drilled at the inner corner to avoid cracking of the board. Wall ducts for pipes etc can be made with a keyhole saw (diamond tipped or HHS bi-metal).

Handling and Storage

General information

Handling and Storage

Swisspearl boards should be stored on a flat and dry level surface. The plastic cover is for dust protection only during transportation and should be removed upon arrival at the building site. Hereafter the pallets should be kept under a roof or covered by a tarpaulin leaving the possibility of ventilation around the boards.

The boards must be lifted off the pallet and not drawn over the next board. This will cause scratches and damages on the surface. Note! Max 5 pallets in one stack and always on a substrate with a sufficient carrying capacity.

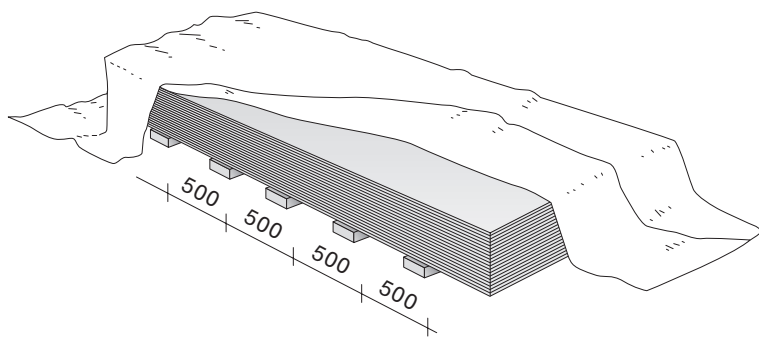

Service

If you have any questions regarding the Swisspearl functional boards, your local Swisspearl representative is ready to assist you with advice and guidance.

Warranty

Warranty conditions can be commissioned at Swisspearl B.V.

Disclaimer

The information contained in this publication and otherwise supplied to users of the Swisspearl's products is based on the Swisspearl's general experience, best knowledge and belief.

However because of factors that fall beyond the Swisspearl's knowledge and control, which can affect the use of the products, no warranty is given or implied with respect to such information. The Swisspearl's policy is one of continuous improvement. Swisspearl therefore reserves the right to alter specifications at any time and without notice.

Colours and textures may vary according to light and weather conditions. Owing to this and limitations of the printing process, colours in this brochure may vary.

Please, ensure that you have the latest version of this publication, by checking that the publication date corresponds with the downloadable version from our website swisspearl.nl. In case of doubt, please contact your local Swisspearl representative. Swisspearl is among the leading players within fibre-cement based building materials, and the second largest in Europe. Swisspearl employs more than 1100 people in 16 European countries and offers a wide range of products and solutions for roofs and facings, internal cladding and lining of ceilings and walls.

Swisspearl is headquartered in Aalborg, Denmark. The manufacturing facilities are situated in Finland, Czech Republic, Poland, Hungary and Italy. These factories are specialized in fibre-cement based productions, drawing on the know-how of the group, which is based on more than 80 of experience.



Info

Swisspearl is one of the leading European manufacturers of multi-capability fibre-cement building products. Our products and solutions add exciting new design opportunities for moulding attractive, durable settings for people's lives. But Swisspearl is more than mere products. We also help make all kinds of design and construction projects easier – as well as more profitable, inspiring and effective.

And for us, all construction also involves building relations with people, making your day better, and helping you make the day better for others.

Making it a day to remember.





Swisspearl Sverige AB

Västberga Allé 5, 10tr
12612 Stockholm
Sverige
+ 46 08 506 608 00
info@se.swisspearl.com

swisspearl.com